



*MÁS ESTABILIDAD
MÁS PRODUCTIVIDAD
MÁS SEGURIDAD*

HD 100

MOTOR	PERKINS 1104D-44TA, EU NRMM 97 / 68 / EC EURO III A Gross Power: 74.5 kW (100 HP) @ 2200 RPM Max Torque: 410 Nm@1400RPM		
TRANSMISIÓN	ZF Power Shift transmission with integral torque converter		
DIRECCIÓN	Power Steering		
SIST. ELÉCTRICO	12V Battery System (180 AH)		
LLANTAS	FRONT	2 WD 4 WD	- 9 x 16 - 16 PR - 12.5/80 x 18 - 12 PR
	REAR	Industrial (Option A) (Option B) Heavy Duty	- 16.9 x 28 - 12 PR - 19.5L x 24 - 12 PR - 14 x 25 - 20 PR
VELOCIDAD	Forward max 37 Km/Hr Reverse max 22 Km/Hr		
SIST. HIDRÁULICO	Smart Technology hydraulics : 3480 psi (240 bar) Pump O/P: 145 LPM@2200 RPM		
PESO	8200 Kgs with Standard GP Bucket option		
CAPACIDADES DE SERVICIO		System	Service
	Hydraulic Tank	120 Ltr	100 Ltr
	Fuel Tank	115 Ltr	-
	Engine Coolant	17 Ltr	15 Ltr
	Engine Oil	10 Ltr	10 Ltr
	Transmission	19.5 Ltr	16 Ltr
	Rear Axle	17 Ltr	17 Ltr
	4WD Front Axle	8 Ltr	8 Ltr
OPCIONES	Ditch Cleaning Bucket Square Hole Bucket Rock breaker Ripper tooth Trench bucket Taper Ditching bucket Multipurpose 6 in I bucket Telescopic Dipper		

DIMENSIONS

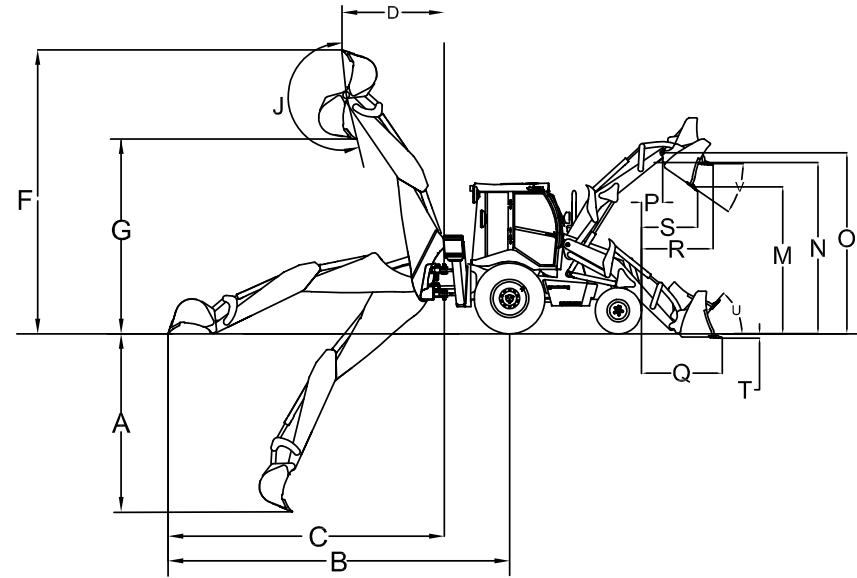
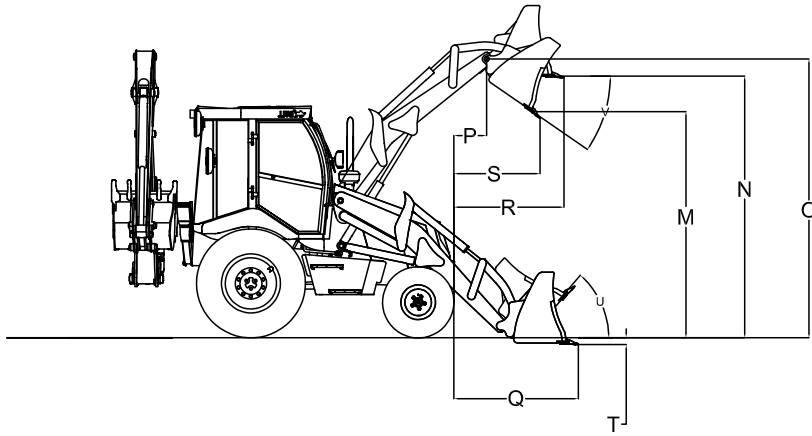

LOADER PERFORMANCE		100HP
Capacidades estándares de la cuchara		1.1 cu.m
I	Altura de descarga	2.96 m
J	Carga sobre altura	3.39 m
K	Altura del pin	3.61 m
L	Alcance del pin hacia adelante	0.42 m
M	Alcance al suelo	1.47 m
N	Alcance en altura máxima	1.28 m
O	Alcance de altura máxima de descarga de la cuchara	0.89 m
P	Prof. de excavación por debajo del nivel del suelo	0.1 m
Q	Giro de retroceso	49°
R	Ángulo de descarga	45°

EXCAVATOR PERFORMANCE		100 HP	
		Retraction STD	Telescopic Dipper (option)
Capacidad estándar del balde		0.27 cu.m	
A	Prof. máxima de excavación	4.60 m	5.59 m
B	Alcance al suelo hasta el centro de la llanta trasera	6.80 m	7.91 m
C	Alcance al suelo para girar al centro	5.50 m	6.60 m
D	Alcance a la alt. máx. para girar al centro	2.85 m	3.56 m
F	Altura máxima de trabajo	5.92 m	6.77 m
G	Altura máxima de carga	4.14 m	5.02 m
H	Potencia de rotación de la cuchara	188°	
Fuerza de arranque de la cuchara		6851 Kgf	
Fuerza de excavación de la cuchara		3316 Kgf	

WORLD'S BEST COMPONENTS



60 / 76 / 96 HP
Proven Kirloskar Engine
100 HP Perkin's Engine



60 / 76 / 96 HP
Carraro (Italy) Transmission
100 HP ZF (German) Transmission



Carlisle Brake
(U.S.A)



World Famous
Hydro Control / Walvoil
(Italy) Valve



AKG (German)
Radiator Cooler



Cassapa (Italy) pump



Carraro (Italy) Axle

MULTIPLE LOADER BUCKET OPTIONS



SALIENT FEATURES

All machines come with advanced features that enhance their performance, productivity and reliability to the highest level



More Bucket Breakout Force & Backhoe Bucket Capacity



Heavy Weight Champion (500 Kg More Weight)



Most fuel efficient backhoe in the world in its class*



The Tallest Dumping Backhoe Loader in the World



Powder Coating : Scratch Resistant Painting



Effy power selector switch Wheel drive / backhoe

EASY TO MAINTAIN AT LOW COST

An Operator friendly machine that facilitates and alerts the operator for regular maintenance.



Engine high temperature Warning Alarm

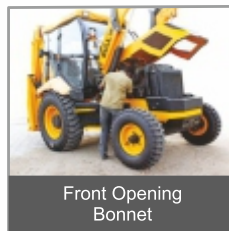

Front Opening Bonnet

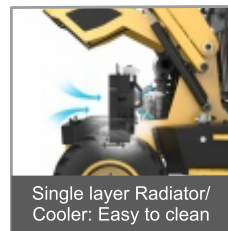

Single layer Radiator/ Cooler: Easy to clean

WORLD CLASS CABIN COMFORT

Incorporated with features for the practical needs of the operator for uninterrupted fatigue free working for longer hours.

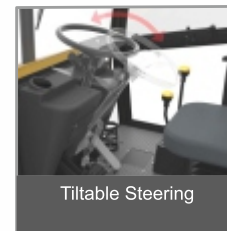

Tiltable Steering



60/76/96 HP Forward reverse Switch



A/C Option



Joystick with Selector Switch

Our other range of TA products

India's No.1
Tractor Attachments



BULL MACHINES PVT.LTD,
Trichy Road, Coimbatore. INDIA
email: sales@bullmachine.com
exports@bullmachine.com

Dealer